

PIC18F4331_hpwm_motor_encoder

Motor and Encoder: DCMTR-203

Available from:

http://www.encodergeek.com/DCMtr_SMALL.html

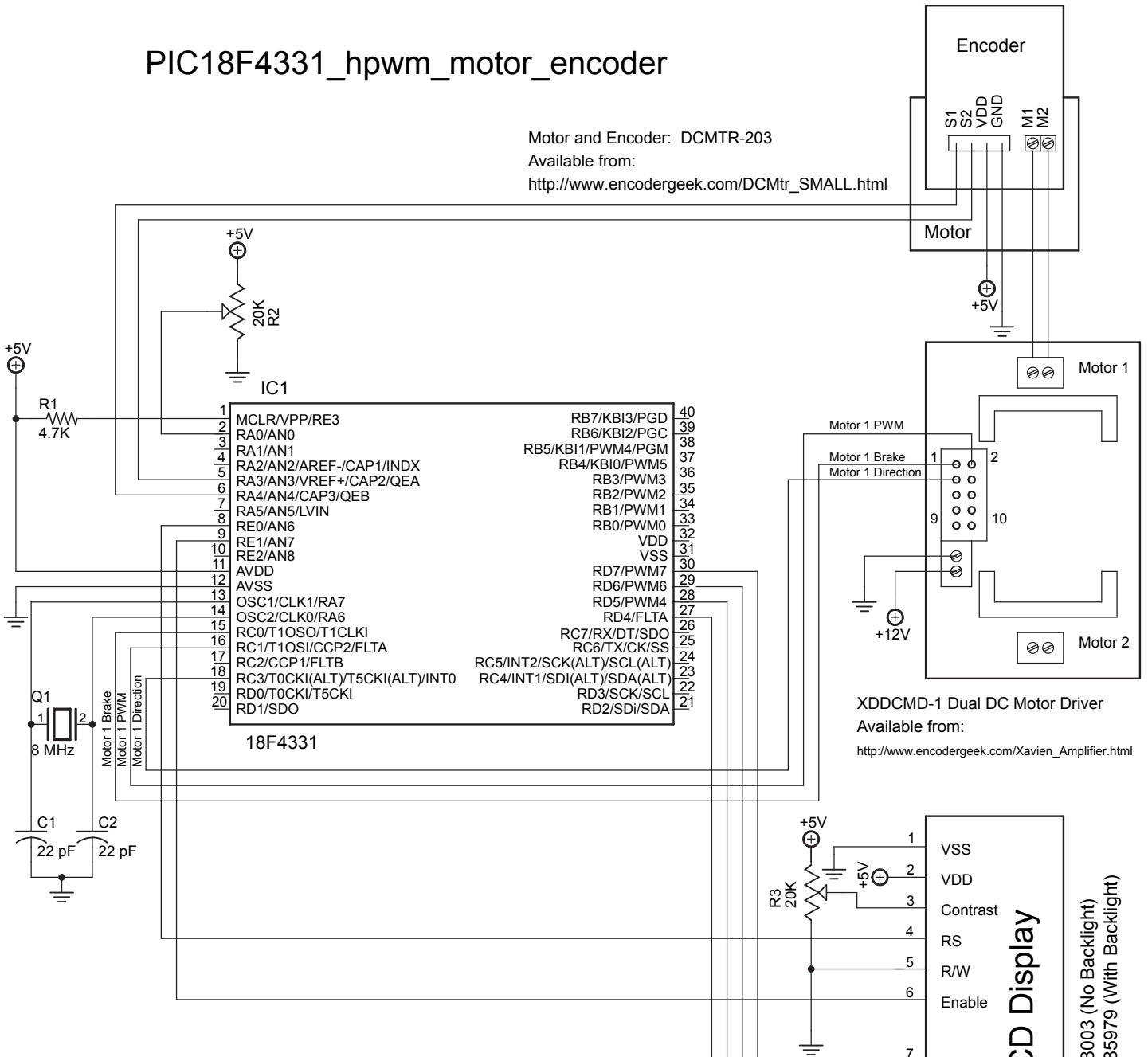

XDDCMD-1 Dual DC Motor Driver
Available from:
http://www.encodergeek.com/Xavien_Amplifier.html

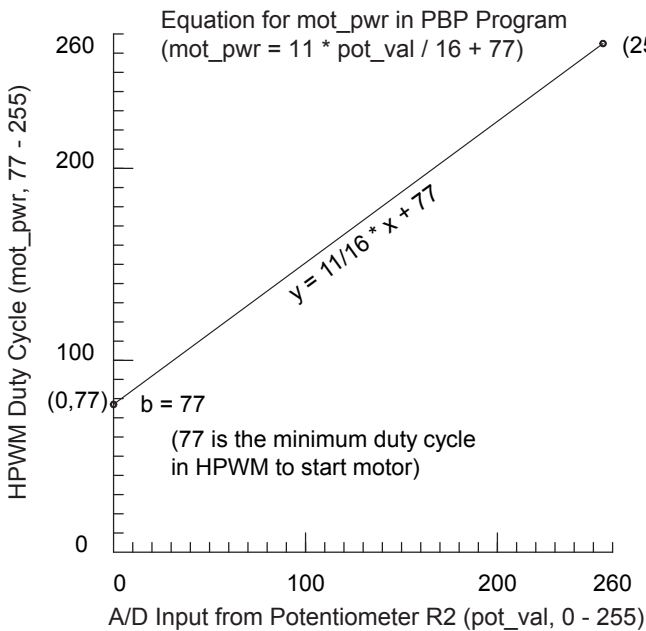

Parallel LCD Display

Jameco Part # 618003 (No Backlight)
Jameco Part # 1585979 (With Backlight)