

Electronics and Robotics I Week 24
Switch Sensors
(4 Hour Class)

- **Administration:**
 - Prayer
- **PicBasic Pro Programs:**
 - General PicBasic Pro Program Listing:
<http://www.cornerstonerobotics.org/picbasic.php>
- **General Statements about Sensors:**
 - Robotic sensors provide information about a robot's environment, enabling it to make decisions about how best to respond to its environment.
 - Sensors measure environmental data like touch, distance, light, sound, strain, rotation, magnetism, smell, temperature, inclination, pressure, or altitude.
 - Sensors should be connected to output devices such as LEDs, piezo buzzers, or other output device to reveal the sensor state. This will assist in troubleshooting mechanical or programming problems.
- **Classification of Sensors:**
 - Mounting:
 - On-Board Sensors: Sensors that are mounted on the robotic platform
 - Global Sensors: Sensors mounted outside the robotic platform that send data back to the robot
 - Sensing:
 - Internal (Proprioceptive): Sensors that sense the internal conditions of the robot itself, such as battery charge or motor speed.
 - External (Exteroceptive): Sensors that sense the environment outside the robot, such as light levels or distance to an object.
 - Analog vs. Digital Sensors:
 - An analog sensor produces a *continuously varying* output value over its range of measurement.
 - On the other hand, a digital sensor has only two states, which are often called "off" and "on." Some sensors that produce a digital output are more complicated. These sensors produce pulse trains of transitions between the 0 volt state and the 5 volt state. With these types of sensors, the shape of this pulse train conveys the sensor's measurement. An example of this type of sensor is the Sharp modulated infrared light detector. With this sensor, the actual element measuring light is an analog device, but signal-processing circuitry is integral to the sensor that produces a digital output.
 - Almost everything in the real world is analog and not digital.
 - Analog sensors input variable voltages into a PIC MCU.
 - The PIC equipped with an analog-to-digital converter (ADC) converts the analog voltage to digital voltage.
 - Analog sensors include:

- Photoresistor
 - Microphone
 - Digital sensors include:
 - SPST switch
 - Digital compass with an internal ADC to convert analog data into digital data
- Passive or Active Sensors:
 - Passive sensors measure energy generated in the environment outside the robot such as photocells.
 - Active sensors such as an ultrasonic range finder emit energy into the environment and subsequently measure the reaction.
- **Switch Sensors:**
 - A switch is an onboard, external, digital, passive sensor:
 - It returns one bit of information, either 1 or 0, making it a binary sensor.
 - Three functions in robotics:
 - Touch sensor: Used to avoid contact with external obstacles
 - Limit switch: Limits motion of a moving part to keep it within the limits of operation
 - Encoder: Used to count rotations of a motor shaft
 - Touch Sensors:
 - Squaring Up with Walls:
 - Two switches can be mounted on a robot to square up a robot with a wall. See the following page.

The robot approaches a wall.

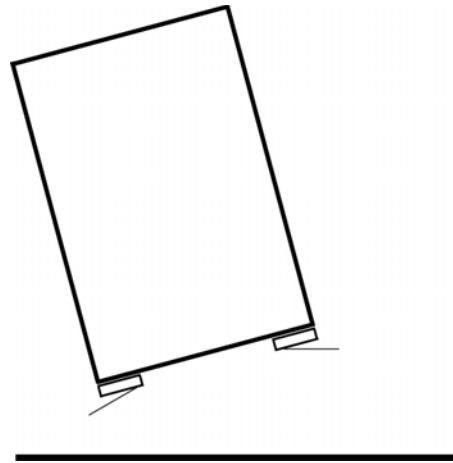

The robots corner touches the wall; the robot responds by turning.

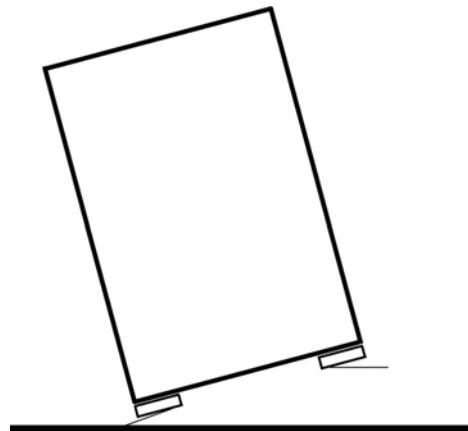

The robot squares with the wall, thereby establishing its orientation.

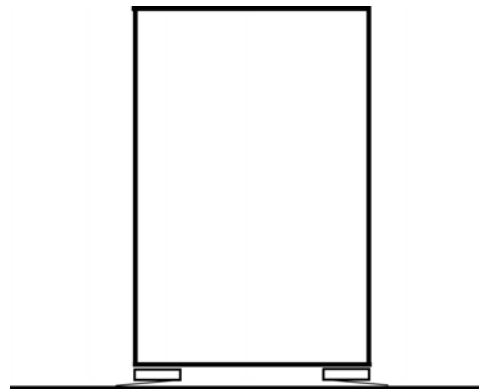

- Perform Switch Sensor LAB 1 – Wall Alignment
- Wall Following Maze Navigation:
 - A robot can navigate through a simple maze by following either the right or left walls from start to finish.

- See the example illustrations below.

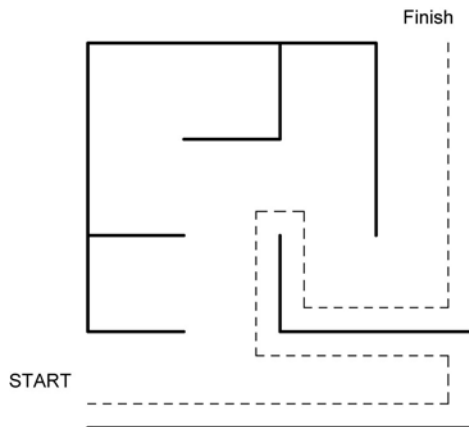

Follow Right Wall

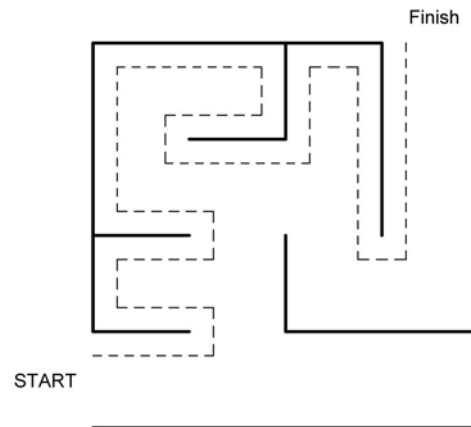

Follow Left Wall

- It is evident from our examples that choosing to follow the right or left walls has a bearing on how long the robot will take to navigate a maze.
- Complete Switch Sensor LAB 2 – Maze Navigation
- Collision Detection:
 - Several switches can be wired in series or parallel and connected to a single digital input port. For example, a touch bumper might have two switches, and the robot only needs to know if *either* of them (#1 OR #2) is closed. It takes less code and less time to check just one digital port and to use parallel switch wiring to implement the logic OR function in hardware.
 - Prevents the robot from stalling against an object
 - Robot is usually moving slowly to give time for the program and actuators to react before a collision occurs.
 - Perform Switch Sensor LAB 3 – Collision Avoidance
- Limit Switch:
 - Determines when a movable part has reached its limiting position or the end of its range, thus avoiding damage to the mechanism
 - When the limit switch is pressed, the driving motor stops and will not start again until it is activated in the opposite direction – away from the limit switch.
 - Perform Switch Sensor LAB 4 – Limit Switch1
 - Perform Switch Sensor LAB 5 – Limit Switch2

Electronics and Robotics I Week 24 Switch Sensor LAB 1 – Wall Alignment

- **Purpose:** The purpose of this lab is to acquaint the student with the ability of robots equipped with switches to align themselves to a wall.
- **Apparatus and Materials:**
 - 1 – Robotic Car Platform
 - 2 – Lever Micro-switches
- **Procedure:**
 - For the student to determine
- **Challenge:**
 - Install two lever switches on your robotic car platform and program the PIC for the car to square up with a wall. Keep your PAUSE command periods short, otherwise when a switch is activated, the program may be executing another command with a lengthy PAUSE and not recognize the activated switch.

Electronics and Robotics I Week 24 Switch Sensor LAB 2 - Maze Navigation

- **Purpose:** The purpose of this lab is to acquaint the student with the use of a switch as a robotic touch sensor and how to use the information returned to the robot for the robot reaction. In particular, the student uses a switch (or switches) sensor mounted on their robotic car to navigate a maze.
- **Apparatus and Materials:**
 - 1 – Robotic Car Platform
 - 1 or 2 – Lever Micro-Switch(es)
- **Procedure:**
 - For the student to determine
- **Challenge:**
 - Install lever switch or switches on your robotic car platform and program the PIC for the car to navigate through the given maze. Again, keep your PAUSE command periods short, otherwise when a switch is activated, the program may be executing another command with a lengthy PAUSE and not recognize the activated switch.

Electronics and Robotics I Week 24 Switch Sensor LAB 3 – Collision Avoidance

- **Purpose:** The purpose of this lab is to acquaint the student on the use of switches mounted on the robotic car for object avoidance.
- **Apparatus and Materials:**
 - 1 – Robotic Car Platform
 - 2 – Lever Micro-switches
- **Procedure:**
 - For the student to determine
- **Challenge:**
 - Install two lever switches on your robotic car platform and program the PIC so the car will avoid objects placed in front of the vehicle. Keep your PAUSE command periods short.

Electronics and Robotics I Week 24 Switch Sensor LAB 4 – Limit Switch1

- **Purpose:** The purpose of this lab is to acquaint the student with wiring limit switches to a DPDT switch that is operated manually.
- **Apparatus and Materials:**
 - 1 – Breadboard
 - 2 – Lever Micro-Switches
 - 1 – DIP DPDT Switch
- **Procedure:**
 - Wire the circuit below.
 - Operate the circuit and observe the results.

Basic Limit Switch Circuit:

- S1 and S2 serve as limit switches
- S3 changes the direction of the motor.

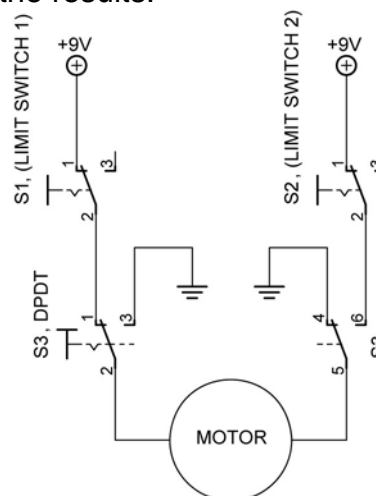

Electronics and Robotics I Week 24 Switch Sensor LAB 5 – Limit Switch2

- **Purpose:** The purpose of this lab is to acquaint the student with programming a PIC microcontroller to control a pair of limit switches.
- **Apparatus and Materials:**
 - 1 – Breadboard
 - 2 – Lever Micro-Switches
 - 1 – DIP DPDT Switch
- **Procedure:**
 - Wire the circuit below. Use the SN754410 circuit wired in the PWM lesson.

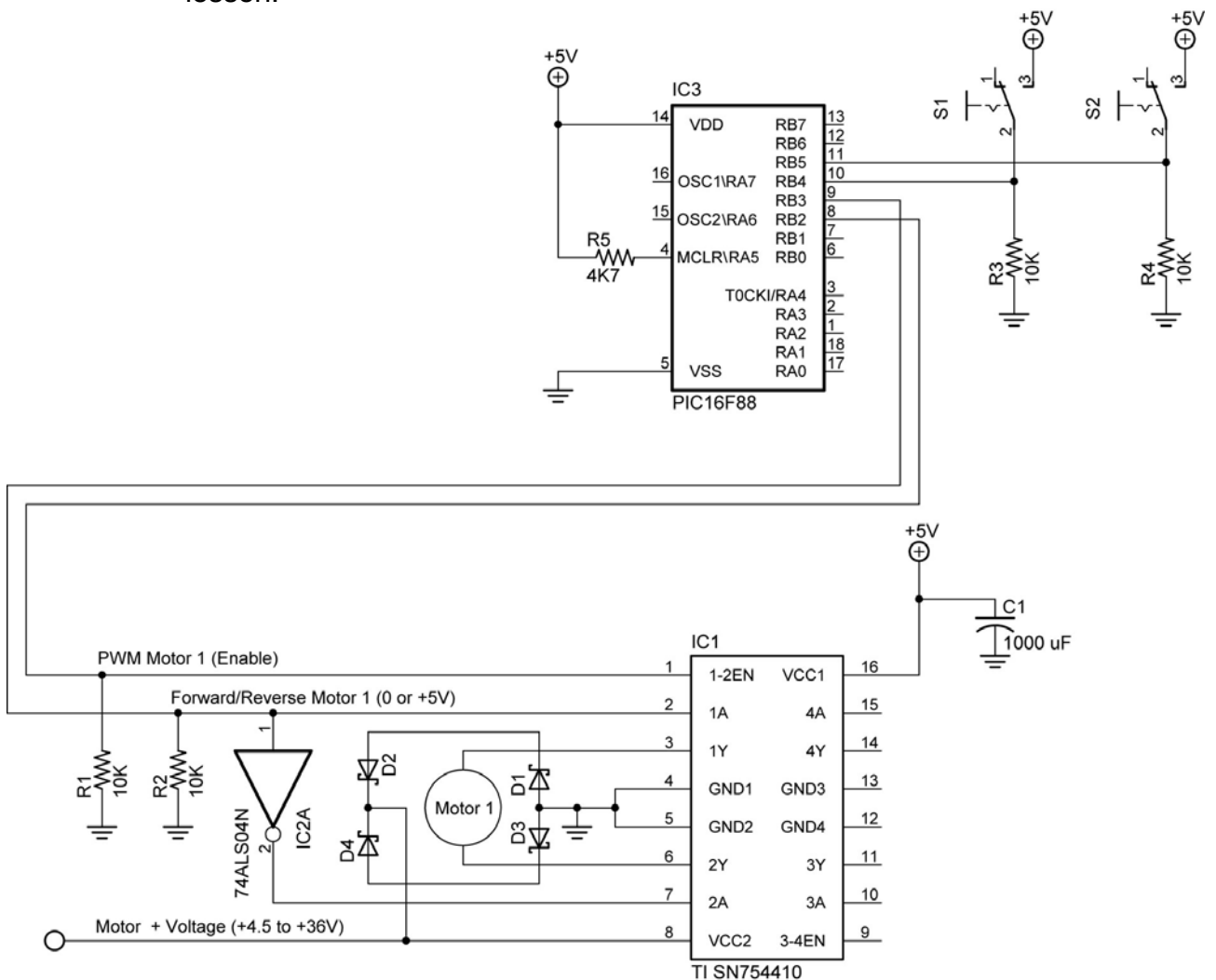

NOTE: D1-D4 1N5817
S1 and S2 are limit switches

- **Challenge:**
 - Program the PIC16F88 to continuously run the given motor and lever system back and forth between the two limit switches.