

Cornerstone Electronics Technology and Robotics I Week 19 Electrical Relays

- Administration:
 - Prayer
 - Turn in quiz
 - Review voltage regulators:

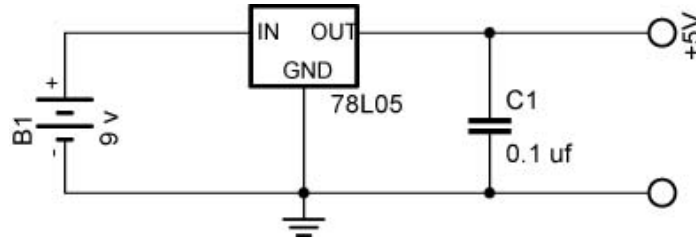

- Review SPST, SPDT, DPST, DPDT switches
http://cornerstonerobotics.org/curriculum/lessons_year1/ER%20Week8,%20Switches,%20Fuses.pdf
- Electricity and Electronics, Section 9.3, **Relays:**
 - Introduction: In many cases, it is impractical to use a manual switch in a circuit. For instance, you would not want to wait for the temperature in your house to rise above a certain level and then manually turn the air conditioning by throwing a manual switch. An automatic switching device would better serve the purpose.
 - General: A relay is an electrically activated switch. It is a device that is used to control a large voltage, large current circuit by means of a low voltage, low current circuit.
 - Three Types of Relays:
 - Mechanical relays
 - High currents, slow switching speeds
 - Reed relays
 - Moderate currents, moderate switching speed
 - Can be damaged by power surges
 - Solid-state relays
 - Wide range of currents, very fast switching speeds
 - Can be damaged by power surges
 - Major Parts of a Mechanical Relay (See Figures 2 and 3):
 - Coil which serves as an electromagnet
 - Armature – the lever arm
 - Contact points
 - Spring

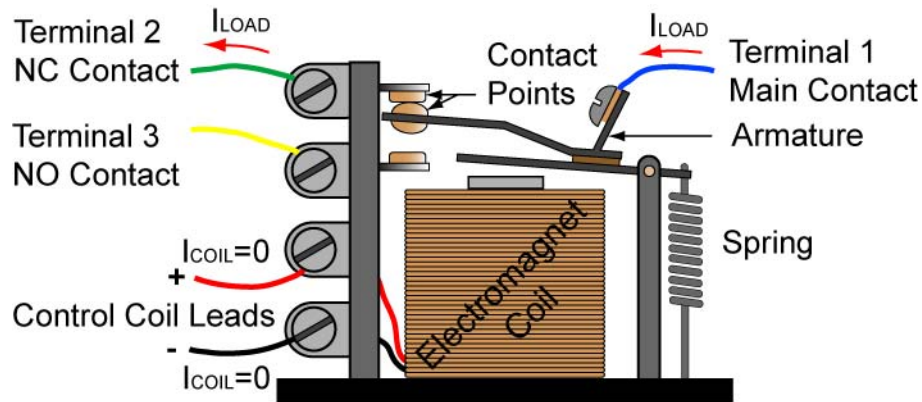

**De-energized SPDT Relay – Spring Holds Armature in Position
Continuity from Terminal 1 (Main Contact) to Terminal 2 (NC Contact)**

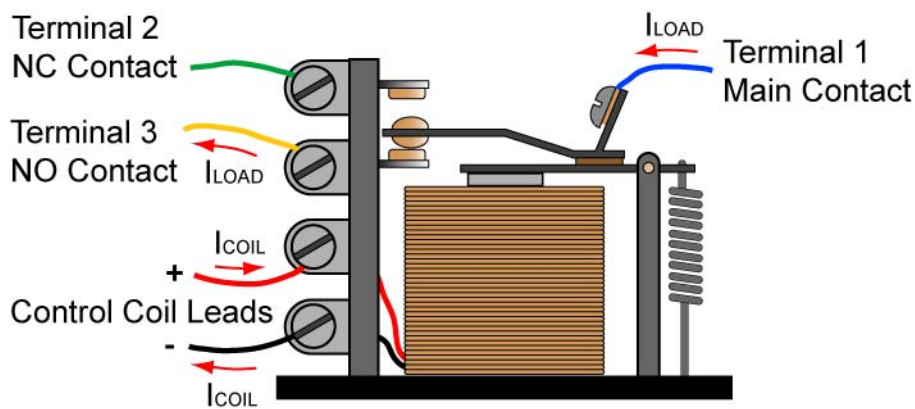

**Energized SPDT Relay – Electromagnet Pulls Armature into Other Position
Continuity from Terminal 1 (Main Contact) to Terminal 3 (NO Contact)**

- Action: When the control circuit of a relay energizes the coil, the coil's attraction force pulls a lever arm called an armature toward the coil. This action turns the secondary circuit on and off. See Figures 2 and 3.

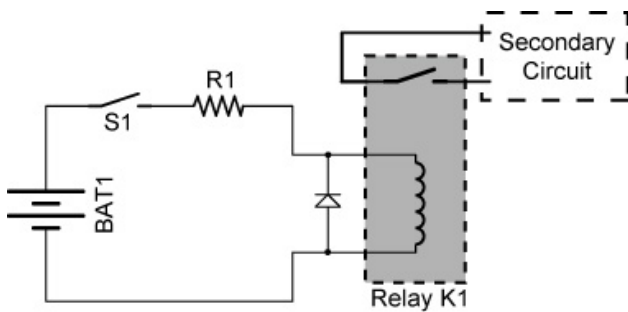

Figure 2

With S1 open, the relay coil is not energized the relay switch remains open.

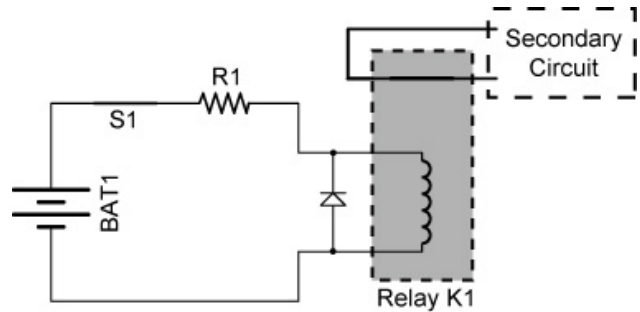
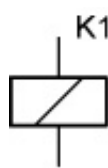

Figure 3

S1 is closed and the relay coil is energized. This causes switch in the relay K1 to close, turning on the secondary circuit.

- The two different voltages can be connected mechanically by a relay. They are not connected electrically.

- Schematic Symbols:



SPST Relay

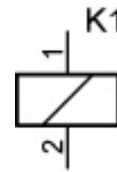
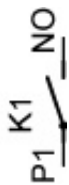

SPDT Relay

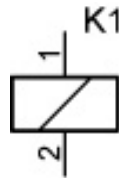
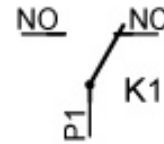

DPST Relay

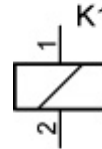
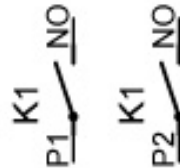

DPDT Relay

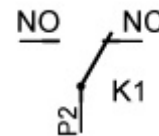
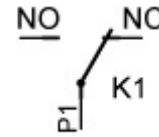

- Show samples
- Perform Electrical Relay Lab 1 – Voltage Separation
- Normally Open (NO) and Normally Closed (NC) Relays:
 - NO/NC relays are similar to NO/NC switches in their operation.
 - NC relays are closed when the relay coil is de-energized.
 - NO relays are open when the relay coil is de-energized.
 - SPDT & DPDT relays have both NO & NC contacts.
 - See: <http://tams-www.informatik.uni-hamburg.de/applets/hades/webdemos/05-switched/20-relays/relay.html>
- Just as a SPDT switch can act as a SPST switch, a SPDT relay can serve as a SPST relay by not making connection to one of the contacts.
- Advantages:
 - An electrical equipment operator is exposed to lower, safer control voltages rather than high equipment voltages.
 - Equipment can be controlled from remote locations.
 - Smaller wires can be run from the control room to the equipment.
 - Relays can have a rapid switching action.
- Using Relays vs. Transistor Switches:
 - Transistors cannot switch AC or high voltages (such as mains electricity) and they are not usually a good choice for switching large currents (> 5A).
 - Advantages of relays compared to a transistor:
 - Relays can switch AC and DC, transistors can only switch DC.
 - Relays can switch high voltages, transistors cannot.
 - Relays are a better choice for switching large currents (> 5A).
 - Relays can switch many contacts at once.

- Disadvantages of relays compared to a transistor:
 - Relays are bulkier than transistors for switching small currents.
 - Relays cannot switch rapidly, transistors can switch many times per second.
 - Relays use more power due to the current flowing through the coil.
 - Relays require more current than many ICs can provide, so a low power transistor may be needed to switch the current for the relay's coil.

(Relay/transistor comparison from: <http://www.kpsec.freeuk.com/trancirc.htm>)

○ Notes:

- The voltage across the relay coil should be within 25% of the relay specification.
- If current flow through a relay coil is suddenly interrupted, the coil will produce a very large voltage spike in the reverse direction of the applied voltage. To handle these reverse voltage spikes, place a transient suppressor diode across the relay's coil.

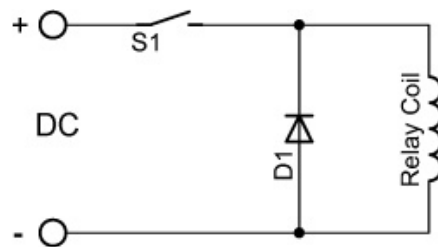

Transient Suppressor Diode D1 for a DC Driven Relay Coil

- Perform Electrical Relay Lab 2 – Relay Application 1
- Reed Relays:
 - External permanent magnet or electromagnet
- Buzzers:
 - Demonstrate an AC buzzer using a function generator.
 - Perform Electrical Relay Lab 3 – Relay as a Buzzer
- Magnetic Circuit Breakers:
 - Operation: Once a fault is detected, contacts within the circuit breaker must open to interrupt the circuit; some mechanically stored energy within the breaker is used to separate the contacts. The stored energy may be in the form of springs.
 - Show samples.
- Magnetic Shields:
 - Magnetic shields prevent magnetic fields from interfering with electrical circuits.
 - The magnetic lines of force follow the path of least resistance.
- Perform Electrical Relay Lab 4 – Relay Application 2
- Perform Electrical Relay Lab 5 – Relay Application 3 – Controlling a DC Motor Direction with Relays

Electronics Technology and Robotics I Week 19 Electrical Relay LAB 1 – Voltage Separation

- **Purpose:** The purpose of this lab is to demonstrate that the voltage source which controls a relay coil can be separate from the voltage source that controls the secondary circuit.
- **Apparatus and Materials:**
 - 1 – Breadboard with a +5 V and +9 V Power Supplies
 - 1 – 1N4004 Diode
 - 1 – SPST Relay (Digikey # Z945-ND)
<http://search.digikey.com/scripts/DkSearch/dksus.dll?Detail?name=Z945-ND>
 - 1 – SPST Switch
 - 1 – 1K Resistor
 - 1 – LED
- **Procedure:**
 - Build Relay Circuit 1 on your breadboard. The circuit uses a voltage source of +5 V to energize the relay coil and a separate a voltage source of +9 V to power the LED circuit.
 - Notice that the two circuits in Relay Circuit 1 are not connected electrically. Their interaction is by the coil generating a magnetic field which closes the contacts (switch) in the relay.

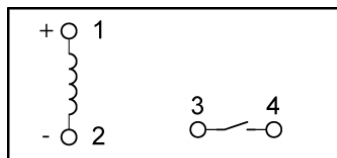

K1 (Z945-ND Top View)

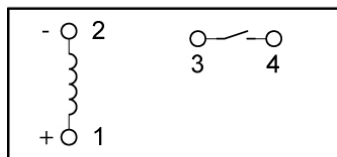

K1 (Z945-ND Bottom View)

SPST Relay Wiring Diagram

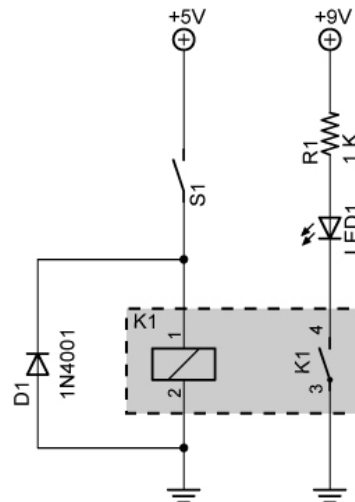

Relay Circuit 1

- **Results:**

Position of Switch	LED Response
S1 Open	
S1 Closed	

- **Conclusions:**
 - The data sheet for the relay states, “When mounting two or more relays side by side, provide a minimum space of 3 mm between relays.” Why?

Electronics Technology and Robotics I Week 19 Electrical Relay LAB 2 – Relay Application 1

- **Purpose:** The purpose of this lab is to demonstrate an application of a relay.
- **Apparatus and Materials:**
 - 1 – Breadboard with a +5 V Power Supply
 - 1 – 1 K Tripot
 - 1 – Photoresistor
 - 1 – 4.7 K Resistor
 - 2 – 1 K Resistors
 - 1 – 2N2222A NPN Transistor
 - 1 – 1N4001 Diode
 - 1 – LED
 - 1 – SPST Relay (Digikey # Z945-ND)

<http://search.digikey.com/scripts/DkSearch/dksus.dll?Detail?name=Z945-ND>
- **Procedure:**
 - Wire the following light activated relay circuit:

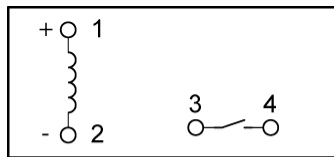

K1 (Z945-ND Top View)

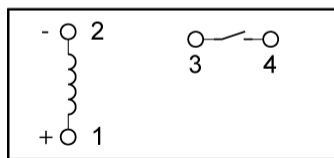

K1 (Z945-ND Bottom View)

SPST Relay Wiring Diagram

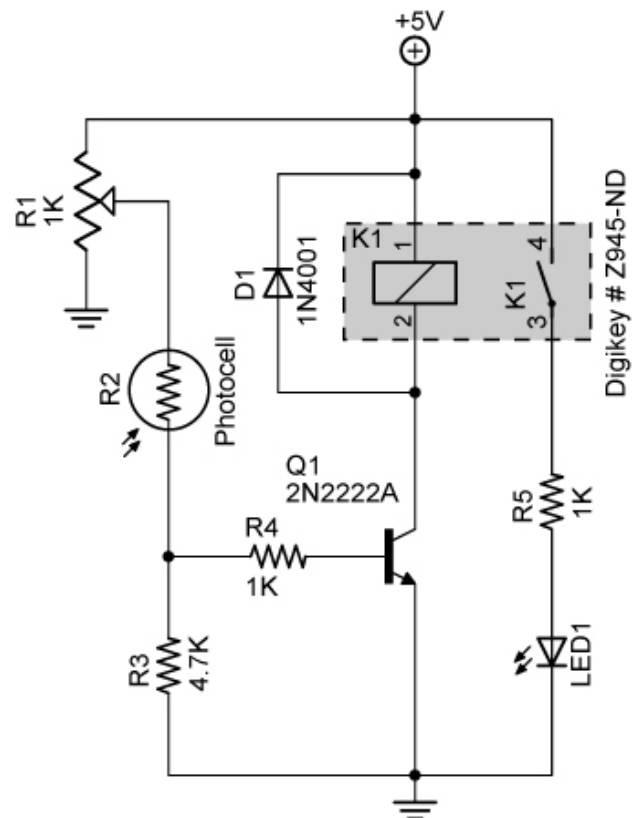

Light Activated Relay Circuit

Electronics Technology and Robotics I Week 19 Electrical Relay LAB 3 – Relay as a Buzzer (Oscillator)

- **Purpose:** The purpose of this lab is to demonstrate that a relay can act as a buzzer (oscillator). Also the student must design and build a relay circuit.
- **Apparatus and Materials:**
 - 1 – Breadboard with +12 V Power Supply
 - 1 – SPST Switch
 - 1 – 1N4001 Diode
 - 1 – 470 uF Capacitor
 - 1 – DPDT Relay (Digikey # 255-1002-5-ND)
<http://search.digikey.com/scripts/DkSearch/dksus.dll?vendor=0&keywords=255-1002-5-nd>
- **Procedure:**
 - Wire a DPDT relay to become a buzzer using the following circuit.
Note that Pin 1 on the relay coil is the positive connection. Also note that Pin 10 is not connected directly to ground but to Pin 8.
Close the switch for only a short period of time since the buzzing action will create excessive wear on the relay contacts. Complete the explanation in the conclusions.

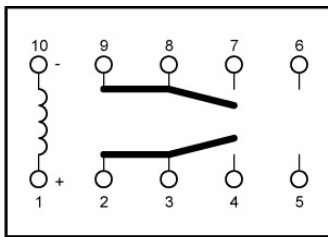

255-1002-5-ND Top View (12V)

DPDT Relay Wiring Diagram

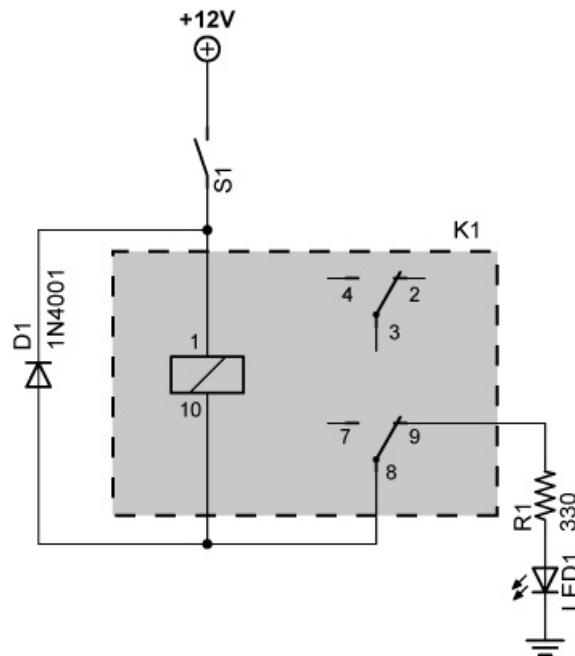

Relay Buzzer Circuit

- Now add a capacitor to the circuit as shown in the following schematic.

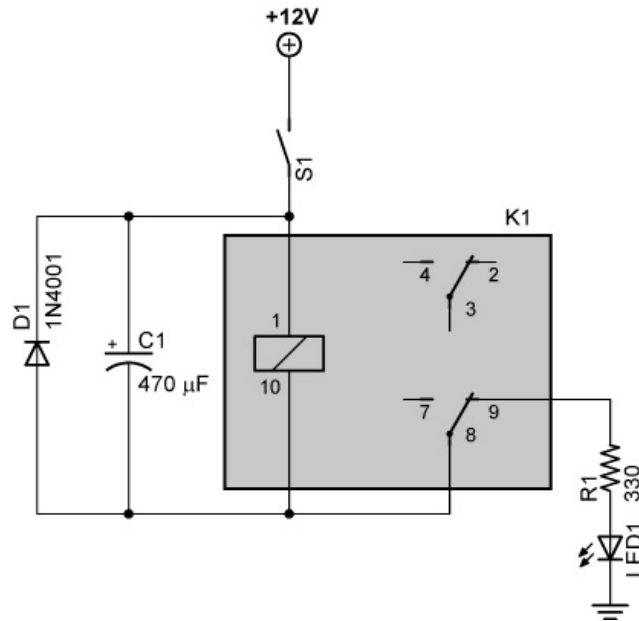

- **Conclusions:**

- Explain the electrical process that makes the relay turns on and off creating the sound of a buzzer.

Electronics Technology and Robotics I Week 19 Electrical Relay LAB 4 – Relay Application 2

- **Purpose:** The purpose of this lab is to demonstrate another application of a relay.
- **Apparatus and Materials:**
 - 1 – Breadboard with a +5 V Power Supply
 - 1 – LM393N Comparator
 - 1 – 220 Resistor
 - 1 – 1 K Resistor
 - 1 – 10 K Resistor
 - 1 – 10 K Tripot
 - 1 – 10 K Thermistor
 - 1 - LED
 - 1 – 2N2907A PNP Transistor
 - 1 – 1N4001 Diode
 - 1 – SPST Relay (Digikey # Z945-ND)
- **Procedure:**
 - Build the temperature activated relay below:

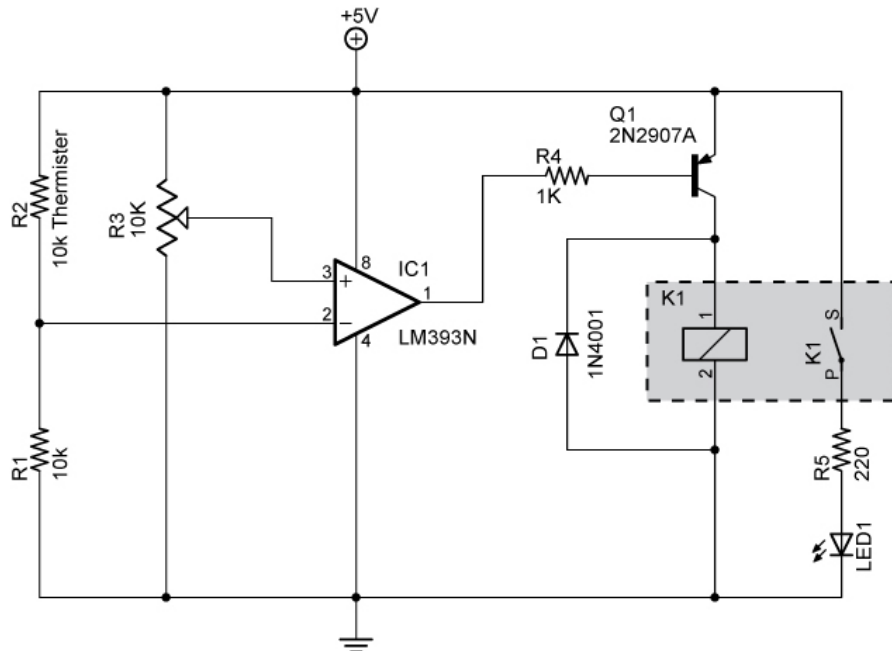

Temperature Activated Relay Circuit

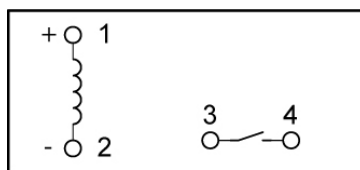

K1 (Z945-ND Top View)

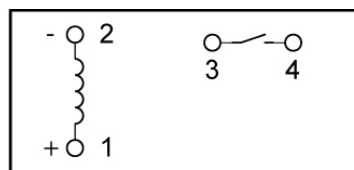

K1 (Z945-ND Bottom View)

SPST Relay Wiring Diagram

Electronics Technology and Robotics I Week 19 Electrical Relay Lab 5 – Relay Application 3 – Controlling a DC Motor Direction with Relays

- **Purpose:** To demonstrate how relays can be used to control the polarity of a dc motor.
- **Apparatus and Materials:**
 - 1 – Breadboard with a +5V and +12V Power Supply
 - 1 – 12V DC Motor (Jameco #155855 or similar)
 - 2 – 1N5817 Schottky Diodes
 - 2 – SPDT DC Reed Relays 5V DC Coil Voltage, (Digi-Key #HE112-ND)
 - Source: http://www.digikey.com/scripts/DkSearch/dksus.dll?WT.z_header=search_go&lang=en&keywords=he112-nd&x=0&y=0&cur=USD
 - Datasheet (Part #HE721C0500): <http://www.hamlin.com/specsheets/HE700.pdf>
- **Procedure:**
 - Build the circuit below:
 - Turn Switches S1 and S2 ON and OFF and fill in the table in results.

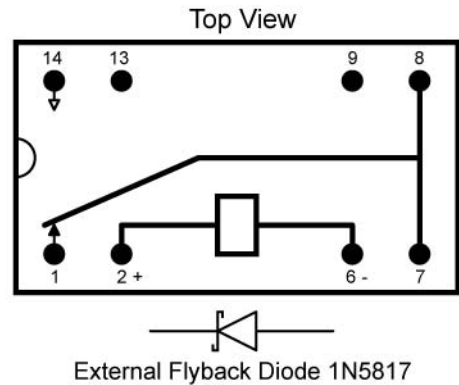
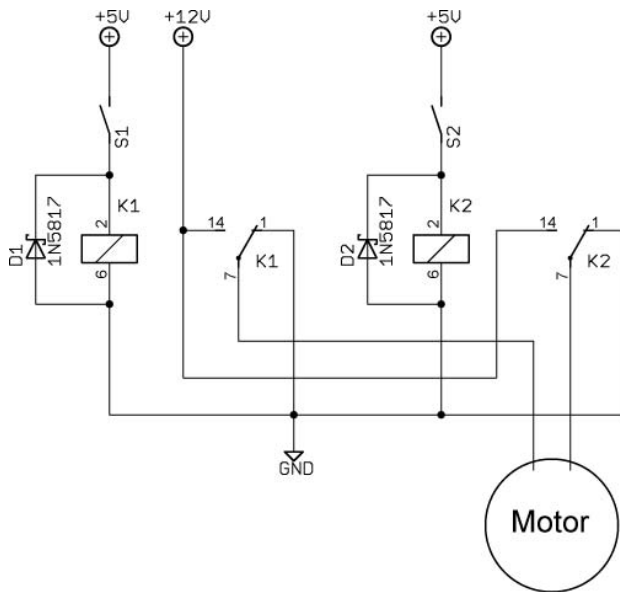

Motor Control Using Two SPDT Relays

Pinout for SPDT Reed Relay

- **Results:**

Motor Relay Logic		
Relay 1	Relay 2	Motor Status

- **Conclusions:**

- Using arrows to represent current, draw the current through the relays and motor in each schematic below. Also show the polarity at the motor terminals and the direction of the motor rotation. If there is no current, just show the polarity at the motor terminals.

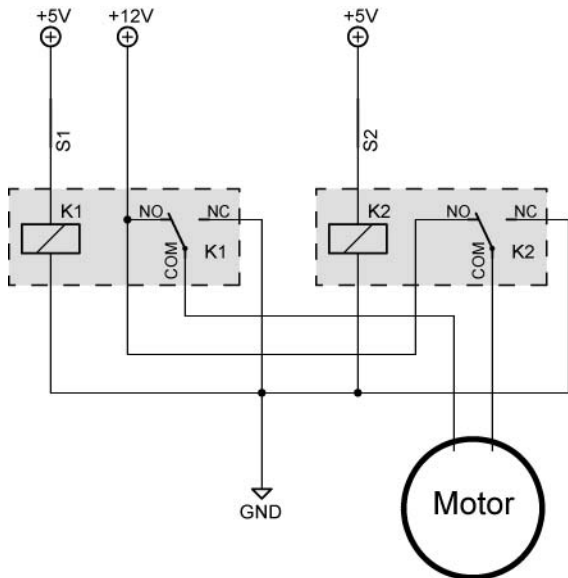

S1 and S2 Closed, Relays 1 and 2 ON OFF

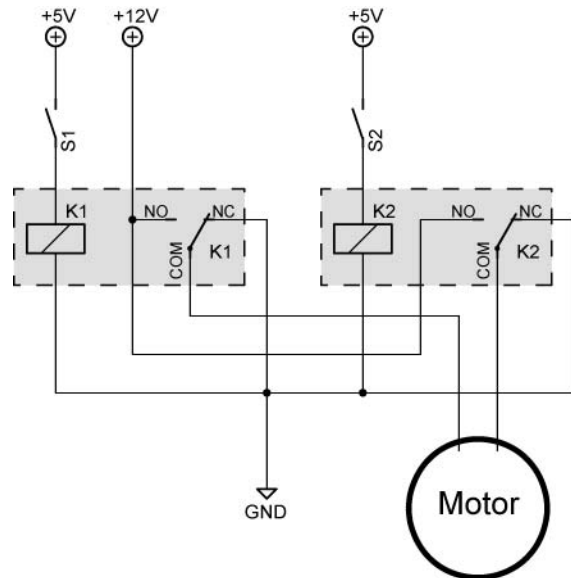

S1 and S2 Open, Relays 1 and 2

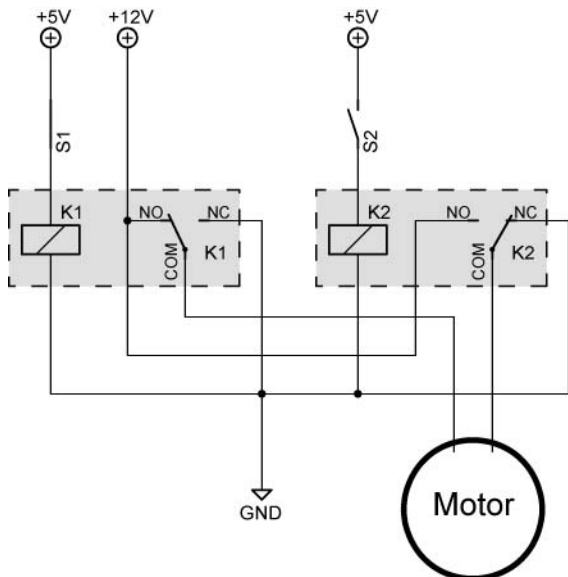

**S1 Closed, S2 Open,
Relay 1 ON, Relay 2 OFF**

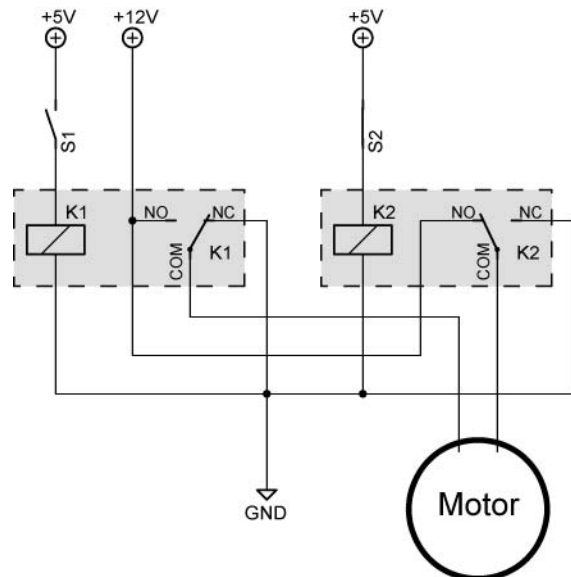

**S1 Open, S2 Closed,
Relay 1 OFF, Relay 2 ON**

• **Answers:**

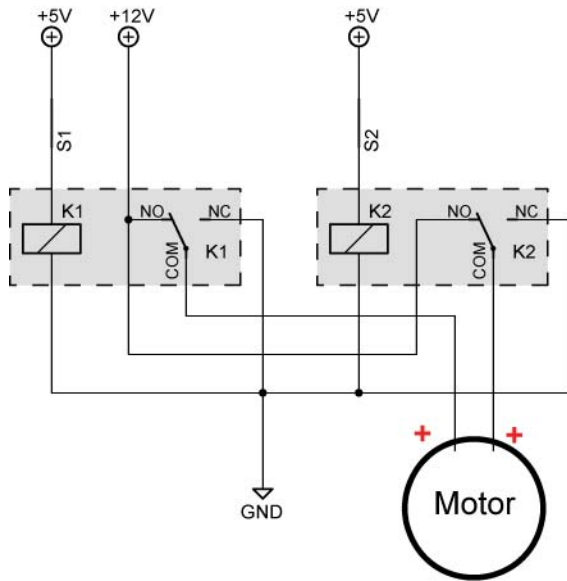

**S1 and S2 Closed, Relays 1 and 2 ON
OFF**

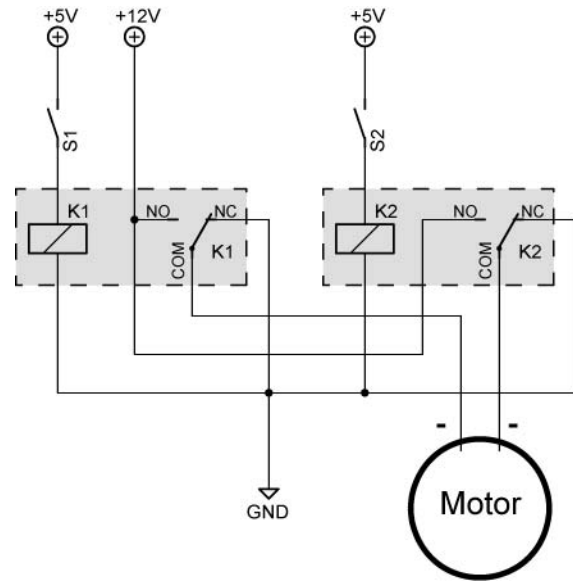

S1 and S2 Open, Relays 1 and 2

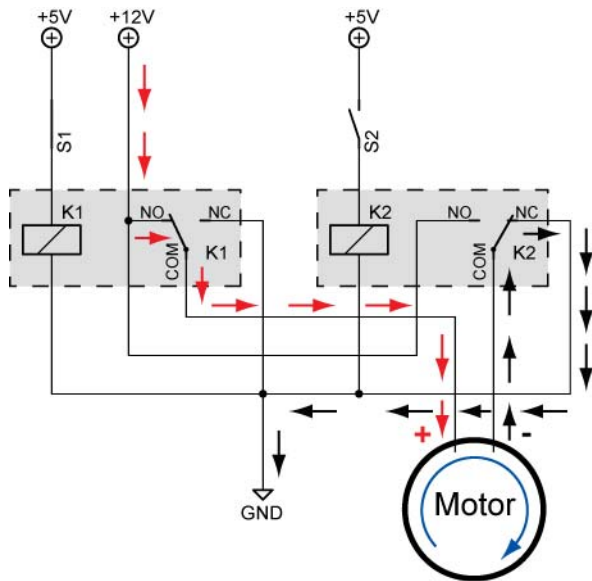

**S1 Closed, S2 Open,
Relay 1 ON, Relay 2 OFF
(Rotation May Be Opposite)**

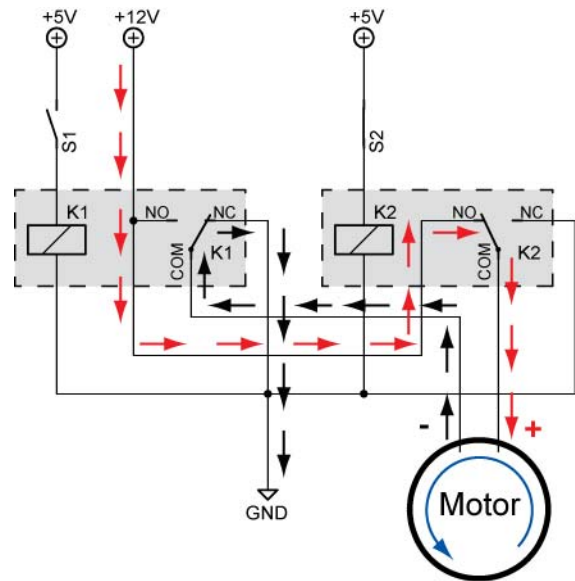

**S1 Open, S2 Closed,
Relay 1 OFF, Relay 2 ON
(Rotation May Be Opposite)**